

V CRIMP 137

FIELD SERVICE & MOBILE WORKSHOP
MOBILE VAN

KEY FEATURES

- Robust and compact design
- Lightweight
- High crimping speed
- Suitable also for 90° elbow fittings
- Cylinder protection
- Remote head mounting option possible



CRIMPING
MACHINES

30

TECHNICAL SPECIFICATIONS

CAPACITY*	NOISE LEVEL
2wb: 1¼" max.	72 dB A
4ws: 1¼" max.	MOTOR
CRIMP RANGE	2.0 kW
4 - 70 mm (0.157 - 2.756")	VOLTAGES
CRIMP FORCE	12 V
137 t	24 V
OPENING WITH DIES	DIMENSIONS
+28 mm (+1.102")	650 x 550 x 610 mm
COMPLETE OPENING	(26 x 22 x 24")
100 mm (3.937")	PACKAGING
MASTER DIE LENGTH	800 x 600 x 830 mm
75 mm (2.952")	(31 x 24 x 33")
STANDARD DIES	NET WEIGHT
15, 18, 21, 24, 27, 30, 33, 36, 39, 42, 45, 48, 51	103 kg (227 lb)
	GROSS WEIGHT
	120 kg (265 lb)

*Indicative capacities depending on hose and fitting type

OPTIONAL



Maintenance Kit



Quick Change Gun



Aluminium Quick Change Gun



Die Storage Panel



Marking Dies



Die Sets for Brake & Air Conditioning Hoses



Battery & Charger

V CRIMP 137 L

FIELD SERVICE & MOBILE WORKSHOP
MOBILE VAN

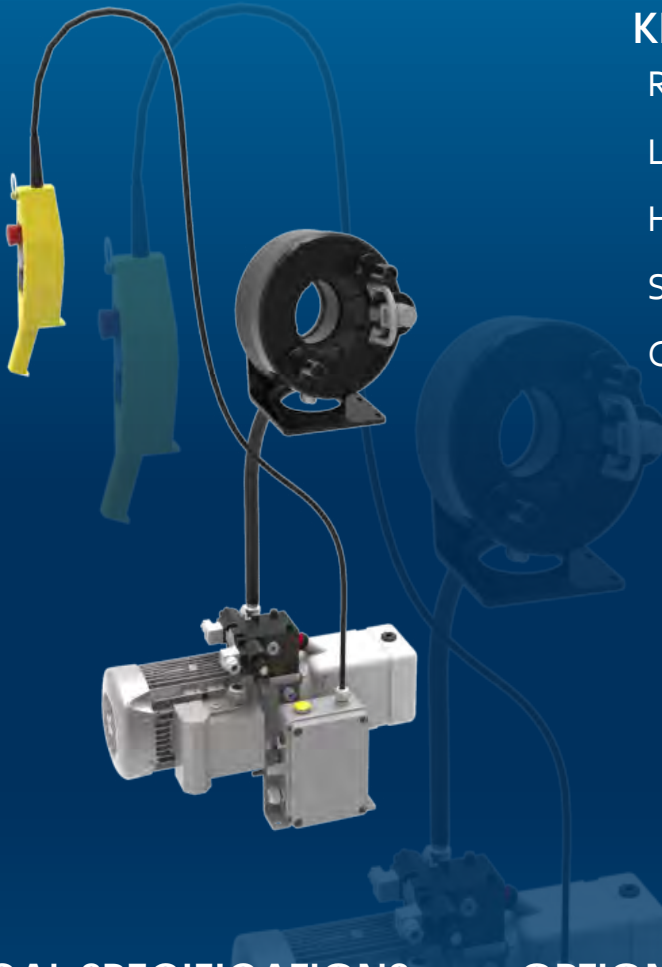

KEY FEATURES

- Robust and compact design
- Lightweight
- High crimping speed
- Suitable also for 90° elbow fittings
- Cylinder protection

TECHNICAL SPECIFICATIONS

CAPACITY*	MOTOR
2wb: 1¼" max.	2.0 kW
4ws: 1¼" max.	VOLTAGES
CRIMP RANGE	12 V
4 - 70 mm (0.157 - 2.756")	24 V
CRIMP FORCE	DIMENSIONS
137 t	250 x 320 x 300 mm
OPENING WITH DIES	(10 x 13 x 12")
+28 mm (+1.102")	PACKAGING
COMPLETE OPENING	800 x 600 x 830 mm
100 mm (3.937")	(31 x 24 x 33")
MASTER DIE LENGTH	NET WEIGHT
75 mm (2.952")	86 kg (190 lb)
STANDARD DIES	GROSS WEIGHT
15, 18, 21, 24, 27, 30, 33, 36, 39, 42, 45, 48, 51	102 kg (225 lb)
NOISE LEVEL	TECHNICAL FEATURES
72 dB A	Dimensions of power pack: 440 x 320 x 320 mm (17 x 13 x 13")
*Indicative capacities depending on hose and fitting type	

OPTIONAL



Maintenance Kit



Quick Change Gun



Aluminium Quick Change Gun



Die Storage Panel



Marking Dies



Die Sets for Brake & Air Conditioning Hoses



Front Die Storage



Battery & Charger

V CRIMP 240

FIELD SERVICE & MOBILE WORKSHOP
MOBILE VAN



KEY FEATURES

- Robust design
- Ergonomic micrometer
- High crimping speed
- Radial movement of the dies
- Cylinder protection
- Remote head mounting option possible

TECHNICAL SPECIFICATIONS

CAPACITY*	MOTOR
2ws: 2" max.	2.0 kW
4ws: 2" max.	VOLTAGES
6ws: 1" max.	12 V
CRIMP RANGE	24 V
4 - 76 mm (0.157 - 2.992")	220/240 V, 3Ph, 50 Hz
CRIMP FORCE	380/415 V, 3Ph, 50 Hz
240 t	208/240 V, 3Ph, 60 Hz
OPENING WITH DIES	380/415 V, 3Ph, 60 Hz
+38 mm (+1.496")	DIMENSIONS
COMPLETE OPENING	650 x 550 x 670 mm
118 mm (4.646")	(26 x 22 x 26")
MASTER DIE LENGTH	PACKAGING
100 mm (3.937")	800 x 600 x 830 mm
STANDARD DIES	(31 x 24 x 33")
15, 18, 21, 24, 27, 30, 33, 36, 39, 42, 45, 48, 51, 57, 62, 66, 70	NET WEIGHT
NOISE LEVEL	145 kg (320 lb)
72 dB A	GROSS WEIGHT
	180 kg (397 lb)

*Indicative capacities depending on hose and fitting type

OPTIONAL



Maintenance Kit



Quick Change Gun



Aluminium Quick Change Gun



Die Storage Panel



Marking Dies



Die Sets for Brake & Air Conditioning Hoses



Front Die Storage



Battery & Charger

V CRIMP 240 L

FIELD SERVICE & MOBILE WORKSHOP
MOBILE VAN



KEY FEATURES

- Robust design
- Ergonomic micrometer
- High crimping speed
- Radial movement of the dies
- Cylinder protection

TECHNICAL SPECIFICATIONS

CAPACITY*

2wb: 2" max.

4ws: 2" max.

6ws: 1" max.

CRIMP RANGE

4 - 76 mm (0.157 - 2.992")

CRIMP FORCE

240 t

OPENING WITH DIES

+38 mm (+1.496")

COMPLETE OPENING

118 mm (4.646")

MASTER DIE LENGTH

100 mm (3.937")

STANDARD DIES

15, 18, 21, 24, 27, 30, 33, 36, 39, 42, 45, 48, 51, 57, 62, 66, 70

NOISE LEVEL

72 dB A

TECHNICAL FEATURES

Dimensions of power pack:

440 x 320 x 320 mm (17 x 13 x 13")

*Indicative capacities depending on hose and fitting type

MOTOR

2.0 kW

VOLTAGES

12 V

24 V

220/240 V, 3Ph, 50 Hz

380/415 V, 3Ph, 50 Hz

208/240 V, 3Ph, 60 Hz

380/415 V, 3Ph, 60 Hz

DIMENSIONS

320 x 360 x 350 mm

(13 x 13.5 x 14")

PACKAGING

800 x 600 x 830 mm

(31 x 24 x 33")

NET WEIGHT

130 kg (287 lb)

GROSS WEIGHT

180 kg (397 lb)

OPTIONAL



Maintenance Kit



Quick Change Gun



Aluminium Quick Change Gun



Die Storage Panel



Marking Dies



Die Sets for Brake & Air Conditioning Hoses



Front Die Storage



Battery & Charger



Ergonomic Micrometer

V CRIMP 350

FIELD SERVICE & MOBILE / CONTAINER WORKSHOP
MOBILE VAN



KEY FEATURES

- Robust design
- Large opening
- High crimping force
- Ergonomic micrometer
- High crimping speed
- Radial movement of the dies
- Cylinder protection
- Remote head mounting option possible

TECHNICAL SPECIFICATIONS

CAPACITY*	MOTOR
2wb: 3" max.	2.0 kW
4ws: 2" max.	VOLTAGES
6ws: 2" max.	12 V
Textile / Suction Hose: 4"	24 V
CRIMP RANGE	220/240 V, 3Ph, 50 Hz
4 - 130 mm (0.157 - 5.118")	380/415 V, 3Ph, 50 Hz
CRIMP FORCE	208/240 V, 3Ph, 60 Hz
350 t	380/415 V, 3Ph, 60 Hz
OPENING WITH DIES	DIMENSIONS
+54 mm (+2.125")	650 x 550 x 750 mm
COMPLETE OPENING	(26 x 22 x 30")
180 mm (7.086")	PACKAGING
MASTER DIE LENGTH	800 x 600 x 830 mm
115 mm (4.528")	(31 x 24 x 33")
STANDARD DIES	NET WEIGHT
15, 18, 21, 24, 27, 30, 33, 36, 39, 42, 45, 48, 51, 57, 62, 66, 70, 73, 76	210 kg (463 lb)
NOISE LEVEL	GROSS WEIGHT
<65 dB A	260 kg (573 lb)
	SAFETY REMARK
	Possible limitations in case of double elbow fittings

*Indicative capacities depending on hose and fitting type

OPTIONAL



Maintenance Kit



Quick Change Gun



Aluminium Quick Change Gun



Die Storage Panel



Marking Dies



Die Sets for Brake & Air Conditioning Hoses



Front Die Storage



Battery & Charger