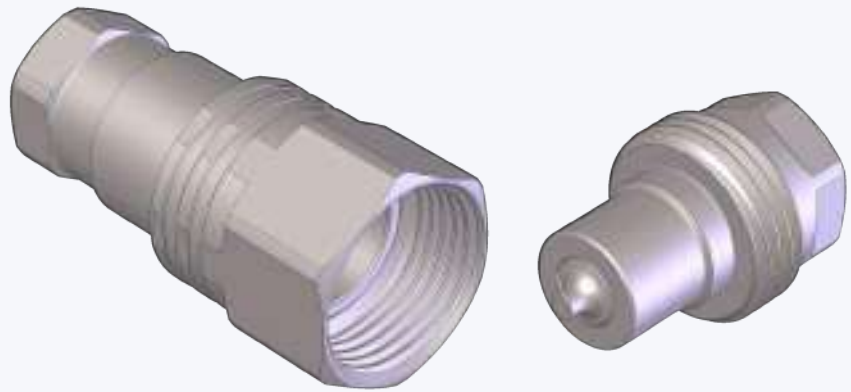

SCREW/VV

VITE/STANDARD
 SCREW COUPLINGS/STANDARD
 SCHRAUBKUPPLUNGEN/STANDARD
 COUPLEURS A VISSER/STANDARD

Caratteristiche tecniche I

- Intercambiabilità: Faster VV
- Occlusione: valvola
- Aggancio: a vite e sfere radiali
- Materiale: acciaio
- Finitura: Zn-Fe (Cr III)
- Filettature: BSP - NPT
- Guarnizioni standard: NBR
- Temperatura d'esercizio: -25 °C +100 °C
- Guarnizioni opzionali: FKM, EPDM o altro
- Pressioni di esercizio: 230-350 bar
- Connessione in pressione: consentita (lato maschio o lato femmina)

Technical data E

- Interchange: VV Faster
- Occlusion: poppet
- Locking: screw and radial balls
- Material: steel
- Finishing: Zn-Fe (Cr III)
- Threads: BSP - NPT
- Standard seals: NBR
- Working temperature: -25 °C +100 °C
- Optional seals: FKM, EPDM or more
- Working pressure: 230-350 bar
- Connection under pressure: allowed (both male or female side)

Nominal size				Max working pressure	Rated flow	Max flow rate	Min burst pressure			Fluid spillage
DNP	BG	ISO	mm				Male	Female	Coupled	
06	1	6.3	6.5	35	12	24	180	140	150	1
10	2	10	9.8	30	23	46	120	180	180	2
13	3	12.5	10.5	30	45	90	100	160	160	3
20	4	19	13.7	25	106	220	100	100	130	10
25	5	25	15.6	23	189	260	60	90	70	15

1 MPa = 145.04 psi • 1 l = 0.264 gal

Technische Merkmale D

- Austauschbarkeit: VV Faster
- Verschluss: ventil
- Kupplung: Schraubweise und Radial Kugeln
- Werkstoff: Stahl
- Ausführung: Zn-Fe (Cr III)
- Gewinde: BSP - NPT
- Standard-Dichtungen: NBR
- Betriebstemperatur: -25 °C +100 °C
- Dichtungen nach Wahl: FKM, EPDM, usw.
- Betriebsdruck: 230-350 bar
- Kuppeln unter Druck: erlaubt (Steckerseite oder Muffeseite)

Caracteristiques techniques F

- Intercangeabilità: VV Faster
- Obturation: clapet
- Accrochage: a vissé et billes radiales
- Matériel: acier
- Traitement: Zn-Fe (Cr III)
- Taraudage: BSP - NPT
- Joints standard: NBR
- Température de service: -25 °C +100 °C
- Joints facultatifs: FKM, EPDM, ect.
- Pression de service: 230-350 bar
- Connexion sous pression: possible (côté male ou femelle)

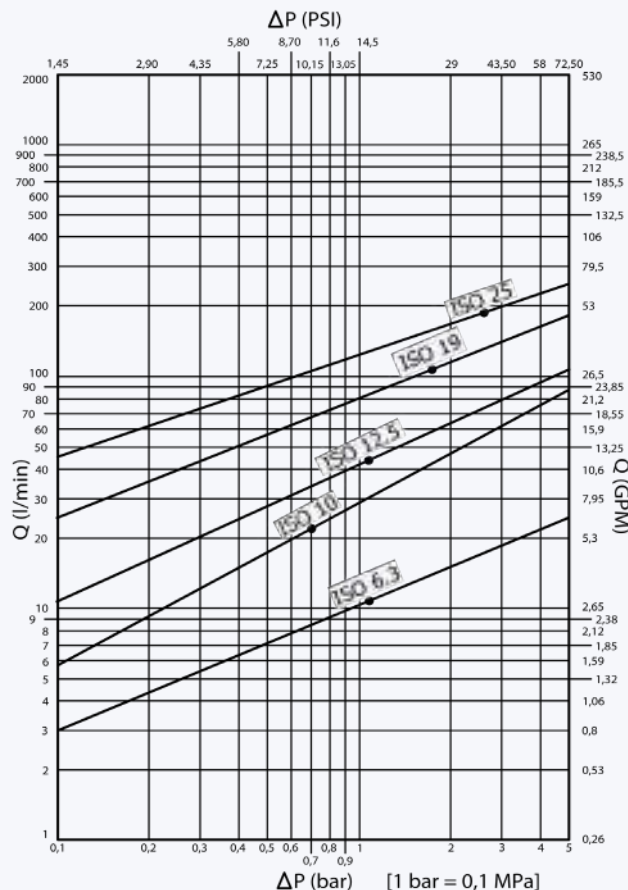

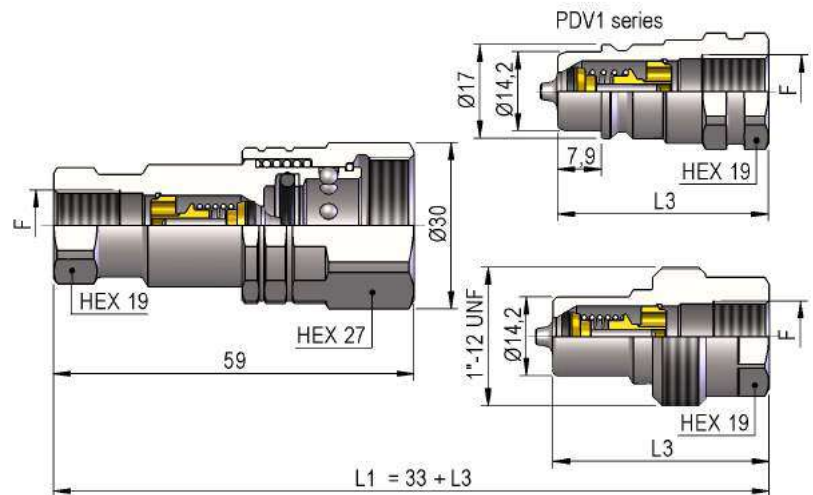
VDV1 DN06 - BG 1 - ISO 6.3

L3	F	STANDARD	FEMMINA - FEMALE - MUFFE - FEMELLE			MASCIO - MALE - STECKER - MALE		
			COD. F	Weight (g)	Packaging (pcs.)	COD. M	Weight (g)	Packaging (pcs.)
33	BSP 1/4"	DIN 3852-2-X	VDV1.0606.002	122	70	VDV1.0606.003	49	150
38	BSP 1/4"	DIN 3852-2-X				PDV1.0606.003	80	200
33	NPT 1/4"	ANSI B1.20.3	VDV1.0606.012	123	70	VDV1.0606.013	50	150
38	NPT 1/4"	B1.20.3				PDV1.0606.013	81	200

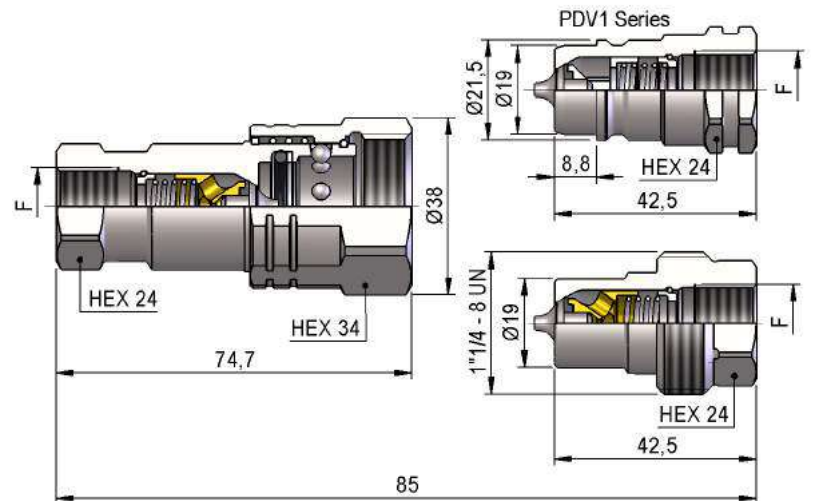
VDV1 DN10 - BG 2 - ISO 10

F	STANDARD	FEMMINA - FEMALE - MUFFE - FEMELLE			MASCIO - MALE - STECKER - MALE		
		COD. F	Weight (g)	Packaging (pcs.)	COD. M	Weight (g)	Packaging (pcs.)
BSP 3/8"	DIN 3852-2-X	VDV1.1010.002	235	48	VDV1.1010.003	95	54
BSP 3/8"	DIN 3852-2-X				PDV1.1010.003	80	200
NPT 3/8"	ANSI B1.20.3	VDV1.1010.012	236	48	VDV1.1010.013	96	54
NPT 3/8"	ANSI B1.20.3				PDV1.1010.013	81	200

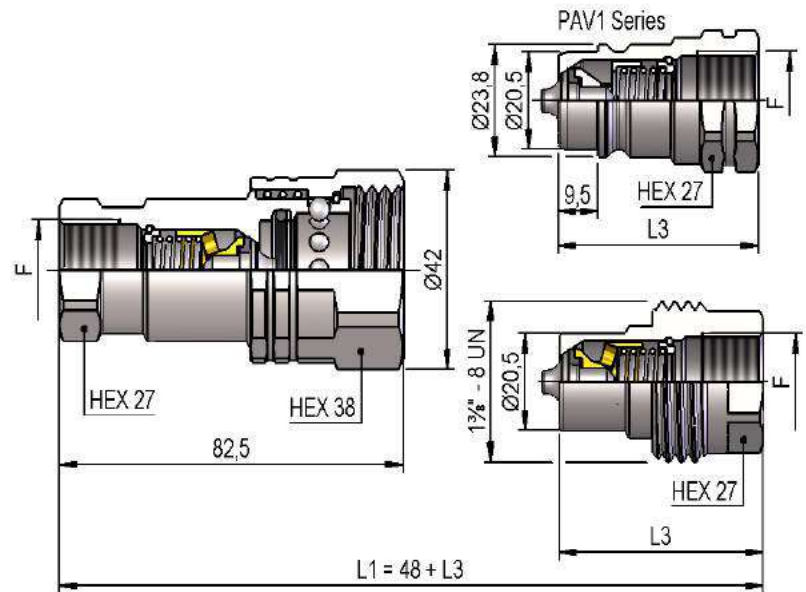
VDV1 DN13 - BG 3 - ISO 12.5

L3	F	STANDARD	FEMMINA - FEMALE - MUFFE - FEMELLE			MASCIO - MALE - STECKER - MALE		
			COD. F	Weight (g)	Packaging (pcs.)	COD. M	Weight (g)	Packaging (pcs.)
49	BSP 1/2"	DIN 3852-2-X	VDV1.1313.002	313	35	VDV1.1313.003	134	45
48	BSP 1/2"	DIN 3852-2-X				PAV1.1313.003	97	200
49	NPT 1/2"	ANSI B1.20.3	VDV1.1313.012	316	35	VDV1.1313.013	137	45
48	NPT 1/2"	ANSI B1.20.3				PAV1.1313.013	98	200

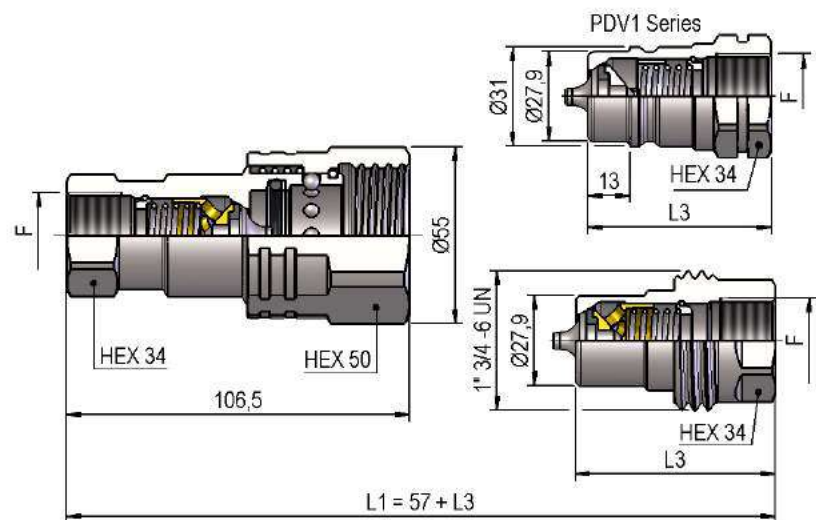
VDV1 DN20 - BG 4 - ISO 19

L3	F	STANDARD	FEMMINA - FEMALE - MUFFE - FEMELLE			MASCIO - MALE - STECKER - MALE		
			COD. F	Weight (g)	Packaging (pcs.)	COD. M	Weight (g)	Packaging (pcs.)
62	BSP 3/4"	DIN 3852-2-X	VDV1.2019.002	688	20	VDV1.2019.003	263	30
57	BSP 3/4"	DIN 3852-2-X				PDV1.2019.003	183	45
62	NPT 3/4"	ANSI B1.20.3	VDV1.2019.012	693	20	VDV1.2019.013	268	30
57	NPT 3/4"	ANSI B1.20.3				PDV1.2019.013	188	45

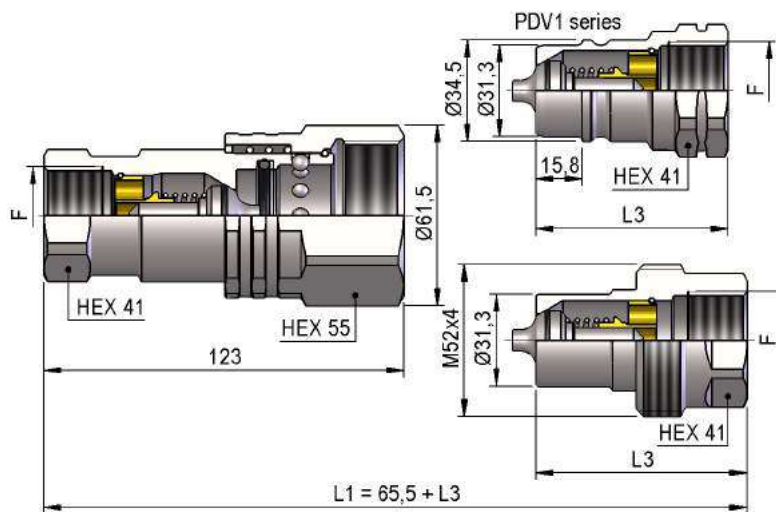
VDV1 DN25 - BG 5 - ISO 25

L3	F	STANDARD	FEMMINA - FEMALE - MUFFE - FEMELLE			MASCIO - MALE - STECKER - MALE		
			COD. F	Weight (g)	Packaging (pcs.)	COD. M	Weight (g)	Packaging (pcs.)
73	BSP 1"	DIN 3852-2-X	VDV1.2525.002	956	18	VDV1.2525.003	410	20
65.5	BSP 1"	DIN 3852-2-X				PDV1.2525.003	282	30
73	NPT 1"	ANSI B1.20.3	VDV1.2525.012	963	18	VDV1.2525.013	417	20
65.5	NPT 1"	ANSI B1.20.3				PDV1.2525.013	289	30

METAL CAPS

NOMINAL SIZE			FEMALE DUST PLUG					MALE DUST					MATERIAL
DNP	BG	ISO	COD. F	Dimensions			Weight (g)	COD. M	Dimensions			Weight (g)	
				D	L	D1			D	L	D1		
06	1	6.3	SVVV.06202	28	190	27	39	SVVV.06203	30	190	27	50	Aluminum
10	2	10	SVVV.10202	34	240	30	71	SVVV.10203	34	240	30	58	Aluminum
13	3	12.5	SVVV.13202	34	240	30	83	SVVV.13203	38	240	30	87	Aluminum
20	4	19	SVVV.20202	53	300	48	194	SVVV.20203	48	290	41	163	Aluminum
25	5	25	SVVV.25202	53	290	41	301	SVVV.25203	58	300	48	264	Aluminum

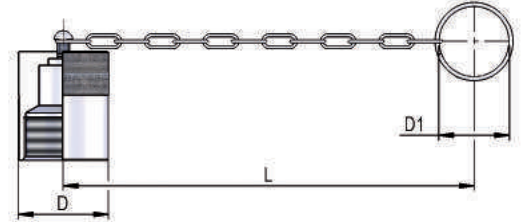
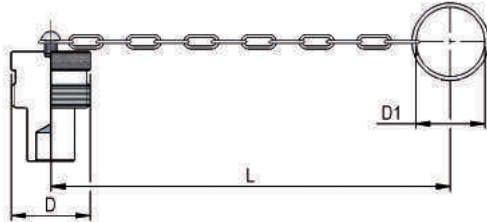
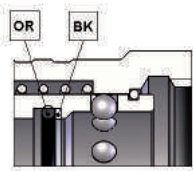
SPARE PARTS

NOMINAL SIZE			FEMALE GASKET	
DNP	BG	ISO	OR (NBR*)	BK (PTFE)
06	1	6.3	PDV.006.120	PDV.006.130
10	2	10	PDV.010.120	PDV.010.130
13	3	12.5	PAV.013.120	PAV.013.130
20	4	19	PDV.019.120	PVV.019.130
25	5	25	PDV.025.120	PDV.025.130

*AL CODICE DELLA GUARNIZIONE IN NBR AGGIUNGERE 'E' PER EPDM O 'V' PER VITON

*TO THE NBR GASKET CODE ADD 'E' FOR EPDM OR 'V' FOR VITON

*ZU DER ARTIKELNR. DER NBR DICHTUNG GEBEN SIE 'E' FUER EPDM ODER 'V' FUER VITON AN

*AU CODE DU JOINT EN NBR JOINDRE 'E' POUR EPDM OU 'V' POUR VITON